

SERIES A CLASS 600 FLANGE

ASME B16.47-2017

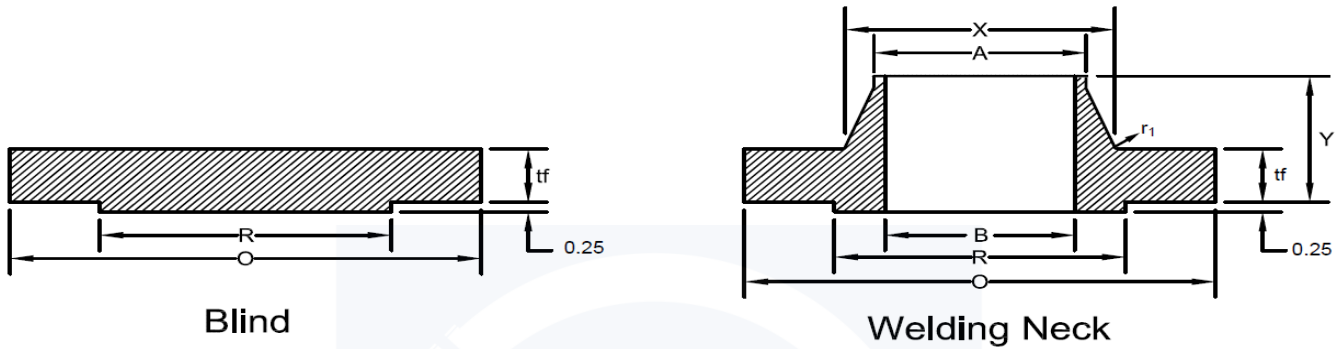

Blind

Welding Neck

1	2	3	4	5	6	7	8	9	10	11	12	13
Minimum Thickness										Bolt		
Nominal Pipe Size	Outside Diameter <i>O</i>	Welding Neck <i>t_f</i>	Blind <i>t_f</i>	Length Through Hub <i>Y</i>	Diameter of Hub <i>X</i>	Diameter of Hub Top <i>A</i>	Diameter of Raised Face <i>R</i>	Minimum Fillet Radius <i>r₁</i>	Bore <i>B</i>	Diameter of Bolt Circle	Number of Holes	Diameter of Holes
26	40.00	4.25	4.94	8.75	29.44	26.00	29.50	0.50	Note-1	36.00	28	2.00
28	42.25	4.38	5.19	9.25	31.62	28.00	31.50	0.50	Note-1	38.00	28	2.13
30	44.50	4.50	5.50	9.75	33.94	30.00	33.75	0.50	Note-1	40.25	28	2.13
32	47.00	4.62	5.81	10.25	36.12	32.00	36.00	0.50	Note-1	42.50	28	2.38
34	49.00	4.75	6.06	10.62	38.31	34.00	38.00	0.56	Note-1	44.50	28	2.38
36	51.75	4.88	6.38	11.12	40.62	36.00	40.25	0.56	Note-1	47.00	28	2.63
38	50.00	6.00	6.12	10.00	40.25	38.00	41.50	0.56	Note-1	45.75	28	2.38
40	52.00	6.25	6.38	10.38	42.25	40.00	43.75	0.56	Note-1	47.75	32	2.38
42	55.25	6.62	6.75	11.00	44.38	42.00	46.00	0.56	Note-1	50.50	28	2.63
44	57.25	6.81	7.00	11.38	46.50	44.00	48.25	0.56	Note-1	52.50	32	2.63
46	59.50	7.06	7.31	11.81	48.62	46.00	50.25	0.56	Note-1	54.75	32	2.63
48	62.75	7.44	7.69	12.44	50.75	48.00	52.25	0.56	Note-1	57.50	32	2.88
50	65.75	7.75	8.00	12.94	52.88	50.00	54.50	0.56	Note-1	60.00	28	3.13
52	67.75	8.00	8.25	13.25	54.88	52.00	56.50	0.56	Note-1	62.00	32	3.13
54	70.00	8.25	8.56	13.75	57.00	54.00	58.75	0.56	Note-1	64.25	32	3.13
56	73.00	8.56	8.88	14.25	59.12	56.00	60.75	0.62	Note-1	66.75	32	3.38
58	75.00	8.75	9.12	14.56	61.12	58.00	63.00	0.62	Note-1	68.75	32	3.38
60	78.50	9.19	9.56	15.31	63.38	60.00	65.25	0.69	Note-1	71.75	28	3.63

Notes:

(1) To be specified by the Customer.

(2) When these flanges are required with flat face, the flat face may be either the full *t_f* dimension thickness plus 0.25 in. or the *t_f* dimension thickness without the raised face height.